

RAMJET RJ-225HD 2 Yard Heavy Duty Hi-Force Compactor

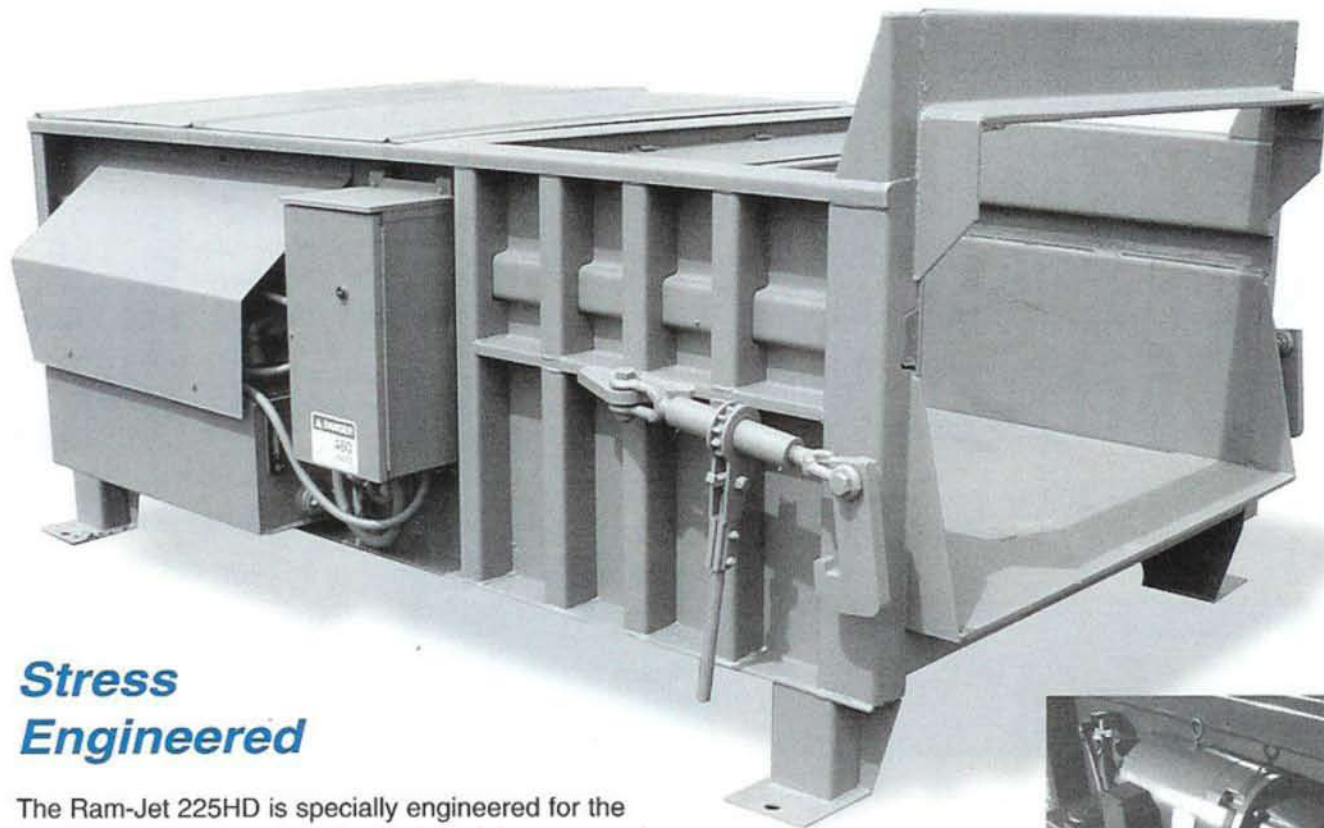

Stress Engineered

The Ram-Jet 225HD is specially engineered for the really tough jobs in waste disposal, and that means the strength is where it belongs... charge box floor features 1/2" steel plate over four 4" steel channels... 1/2" ram face plate, backed with 10" channels that incorporates T-1 plate in high stress areas... 3/8" ram top supported by 8 heavy duty formed crossmembers... and heavily reinforced charge box sides.

Ram Guide System



exclusive design protects the charge box floor from the full force of the packing ram, extending its life and dramatically reducing compaction-rubbing friction.

The packing ram is supported and guided by specially formulated cast iron shoes which ride on replaceable wear strips. This

Side-Mounted Power Unit

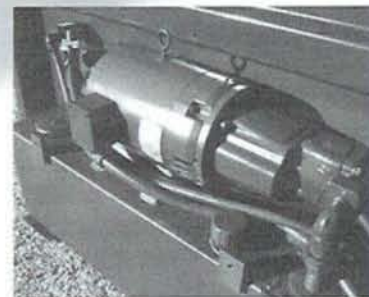

Marathon's new **Side-Mounted Power Unit**, the first in the industry, offers the convenience and ease-of-maintenance of a remote power pack with the space savings of an integrated power pack. This new configuration also eliminates **ALL** electrical components from inside the compactor.

Industrial & Recycling Applications

The RJ-225HD is ideally suited for industrial applications such as the disposal of skids and cartons and for recycling corrugated, aluminum and similar materials. Electrical components, including the control box assembly, carry the UL Label. The 40 1/2" x 60" charge box is 33" deep to make disposal fast and easy.

Specifications:

| | | |
|---------------------|-------------|---------------------|
| Charge Box Capacity | | |
| [Mfrs. Rating] | 2.0 cy | 1.53 m ³ |
| [EIA Rating] | 1.55 cy | 1.18 m ³ |
| Clear Top Opening | 40.5" X 60" | 1029mm x 1524mm |

Performance Characteristics:

| | | |
|---------------------------|-----------|---------|
| Cycle Time | 48 s | 48 s |
| Total Normal Force | 59,400 lb | 264 kN |
| Total Maximum Force | 67,900 lb | 302 kN |
| Normal Ram Face Pressure | 34.1 psi | 235 kPa |
| Maximum Ram Face Pressure | 39.0 psi | 268 kPa |
| Ram Penetration | 14" | 355 mm |

Electrical Equipment:

Electrical Motor 3/60-208/230/460...15 hp.....11.2 kW
 Electrical Control Voltage.....120 VAC.....120 VAC
 UL Labeled Panel Box: Type NEMA 3R, All Circuits Fused
 Standard 2 Button Controls: Keylock Start/ Mushroom Stop
 Connected to 13' (3962mm) Sealtite

Hydraulic Equipment:

Hydraulic Pump Capacity13 gpm.....49.2 L/min.
 Normal Pressure2100 psi.....145 bar
 Maximum Pressure2400 psi.....166 bar
 Hydraulic Cylinder - Bore.....6".....152 mm
Weight.....5450 lbs.....2472 kg

RAMJET

RJ-225HD



▼ The **Pump** on Marathon's high performance **Side-Mounted Power Unit** is secured to a "C" flange motor with a machined bracket that guarantees coupling alignment. The **Limit Switch** (arrow) and all other parts of the power unit are easily accessible for ease-of-maintenance. The **Reset Button** for the Motor Starter is also located on the outside which eliminates entry into the control box.

▼ The **RJ-225HD** features a simplified control system with 2 button operation – key-operated and fully automatic. The heavy duty push button controls are contained in a weatherproof NEMA 13 enclosure. Connected to the power pack with 13' of sealtite, the controls can be located for operator convenience.

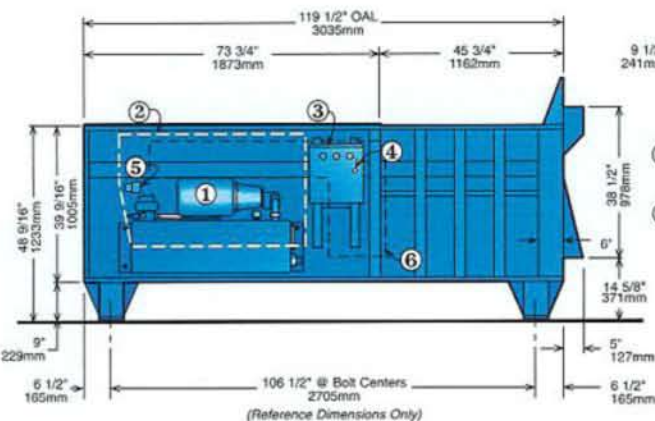

Concrete Pad Requirements

6" (152mm) Thick Reinforced 3000 PSI Concrete (4) 3/4" (20mm) Anchor Bolts (Min.)

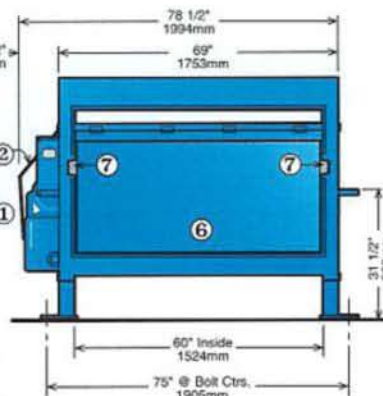

- ① Side-Mount Power Unit
- ② Power Unit Weather Cover
- ③ Control Panel Box
- ④ Motor Starter Reset Button
- ⑤ Limit Switch
- ⑥ Ram
- ⑦ Ram Guide Shoes with Replaceable Wear Strips

Optional Features Available:

▼ **TrashMinder**® advanced method for reporting and measuring container usage and fullness; multi-cycle timer; dual controls; ozone odor control system; hoppers and many other options are also available as well as a full line of compaction containers.

▼ Chutes can be constructed to meet your specifications and needs. They reduce the risk of pilferage of valuable merchandise or tools by eliminating a person's ability to hide items in the trash in order to recover them later from the waste receptacle.

Top View of Typical Compactor & Container Configuration

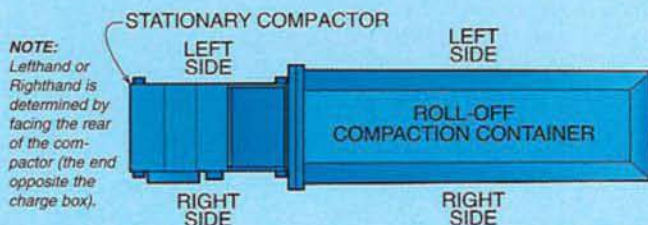

1-800-464-3095



Pictures in this literature are illustrative only. Specifications are subject to change without notice in order to accommodate improvements to the equipment. Certified in compliance with ANSI Regulation Z245.2, all OSHA standards, and certified under WASTEC's Stationary Compactor Certification Program. Products must be used with safe practice and in accordance with said regulations and standards.